

Surveillance mast systems

All Lattix Systems mast systems for the surveillance support systems comply to the latest ICAO frangibility requirements.

All Lattix masts are rigidly full scale crash tested to withstand the forces of wind and extreme weather, and of course the jet blast that might occur on an airfield.

In addition, the Lattix® masts are fully frangible and will give way and absorb any force upon impact, leaving the airplane wing/body as little damaged as possible.

The Lattix surveillance systems are adapted to fit any camera and instrumentation. The system is designed for easy access to instrumentation for maintenance purposes.

Systems available up to 16m.

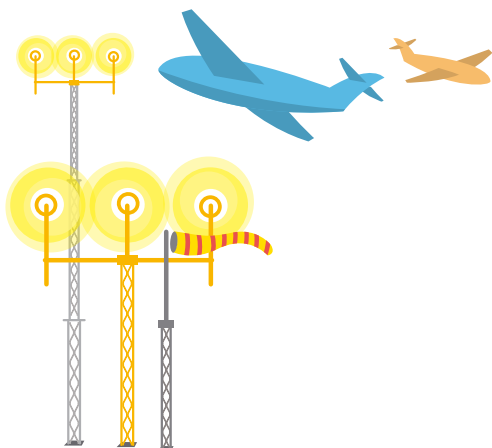
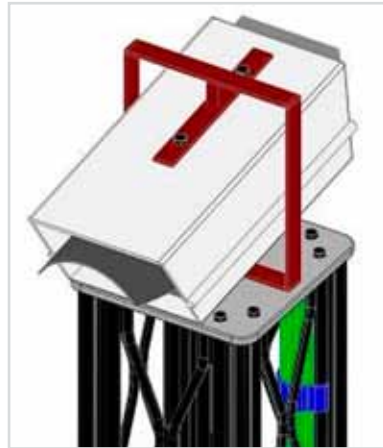
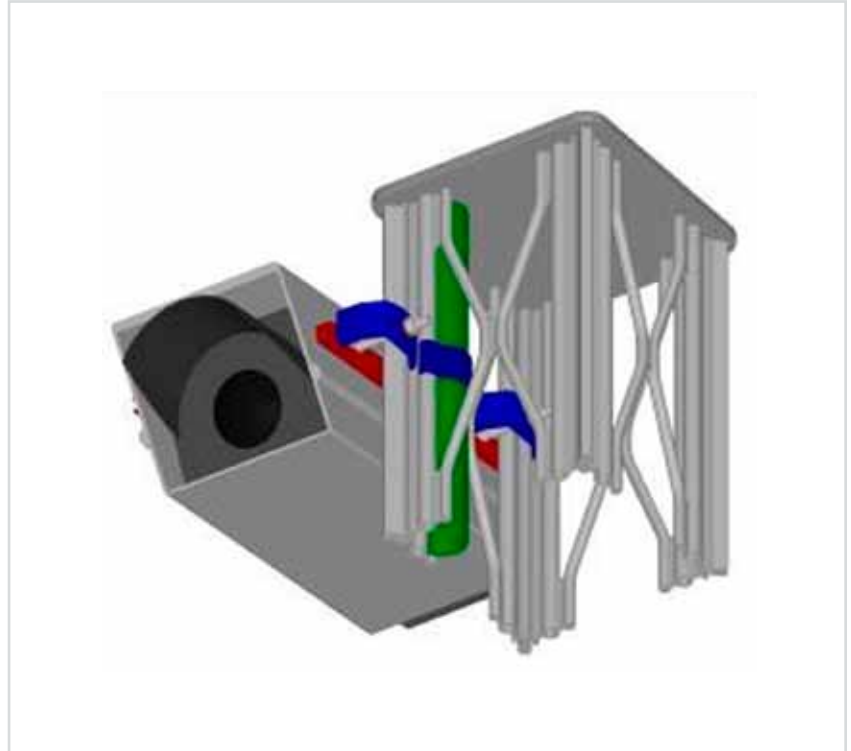

Lattix Systems has delivered frangible mast systems to more than 200 airports in 40 countries.



Approach light systems



Meteorological and weather station systems



Wind cone mast systems



Surveillance mast systems



Localizer support systems



Glidepath mast systems



Floodlight systems



Extra tall masts

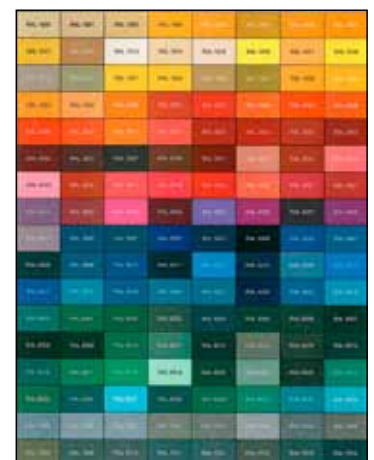
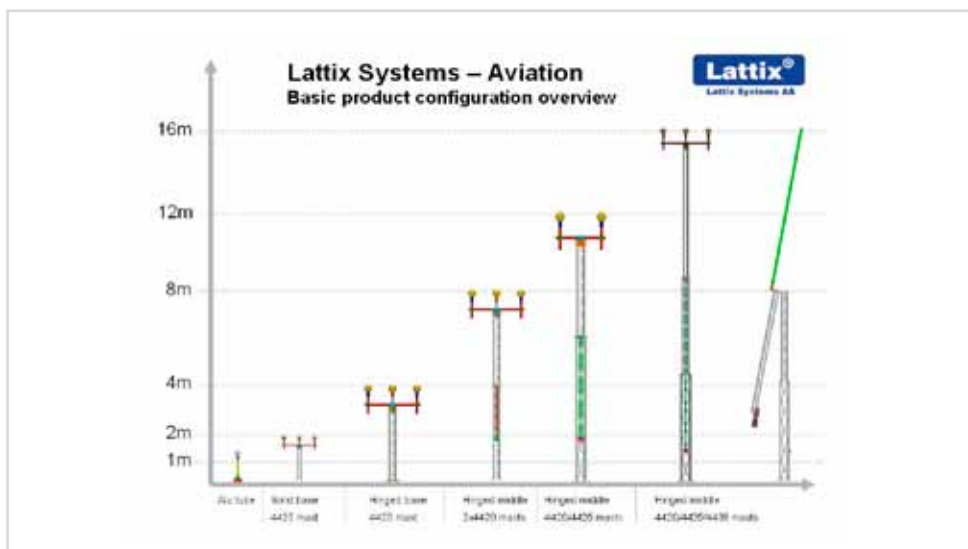

Lattix® masts can be powder coated according to all RAL colors.